

RECOMMENDED SOLDER PASTE: THICKNESS 120μm

- NOTES)
- 1. ALL LEADS CO-PLANARITY SHALL BE 0.1 mm MAX.
 - 2. PER REEL : 8,000 CONNECTORS.
 - 3. AT THE BEGINNING OF THE REEL, 100 mm AT MIN SHALL BE EMPTY POCKETS.
AT THE END OF THE REEL, 160 mm AT MIN SHALL BE EMPTY.
 - 4. CONTACT PLATING SPECIFICATIONS.
CONTACT AREA : GOLD 0.05 μm MIN.
SMT LEAD : GOLD 0.05 μm MIN.
UNDERPLATING : NICKEL 1 μm MIN.
(SURFACE : SEALING)
 - 5. METAL HOLD DOWN PLATING SPECIFICATIONS.
MOUNTING AREA: GOLD 0.05 μm MIN.
UNDERPLATING : NICKEL 1 μm MIN.
 - 6. PEEL FORCE OF COVER TAPE REFERS TO JIS C 0806.

3	PHOSPHOR BRONZE	5	6	PS	PLASTIC REEL (BLACK)
2	PHOSPHOR BRONZE	4	5	POLYESTER	CLEAR (COVER TAPE)
1	LCP	UL94V-0, BLACK	4	PS	CLEAR (EMBOSSED CARRIER TAPE)
NO.	MATERIAL	FINISH, REMARKS	NO.	MATERIAL	FINISH, REMARKS
UNITS	mm	SCALE	10:1	COUNT	0
		DESCRIPTION OF REVISIONS	DESIGNED	CHECKED	DATE
		DIS-H-003977	SH. HOSODA	TS. MIYAZAKI	09.06.18
APPROVED : KH. IKEDA		08.10.24	DRAWING NO. EDC3-318072-01		
CHECKED : KY. MIDORIKAWA		08.10.24	PART NO. BM10NB(0.8)-50DS-0.4V(51)		
DESIGNED : NY. YAMASHIRO		08.10.24	CODE NO. CL684-6102-6-51		
DRAWN : SH. HOSODA		08.10.24	1/2		

ENBOSSED CARRIER TAPE DIMENSHONS(FREE)

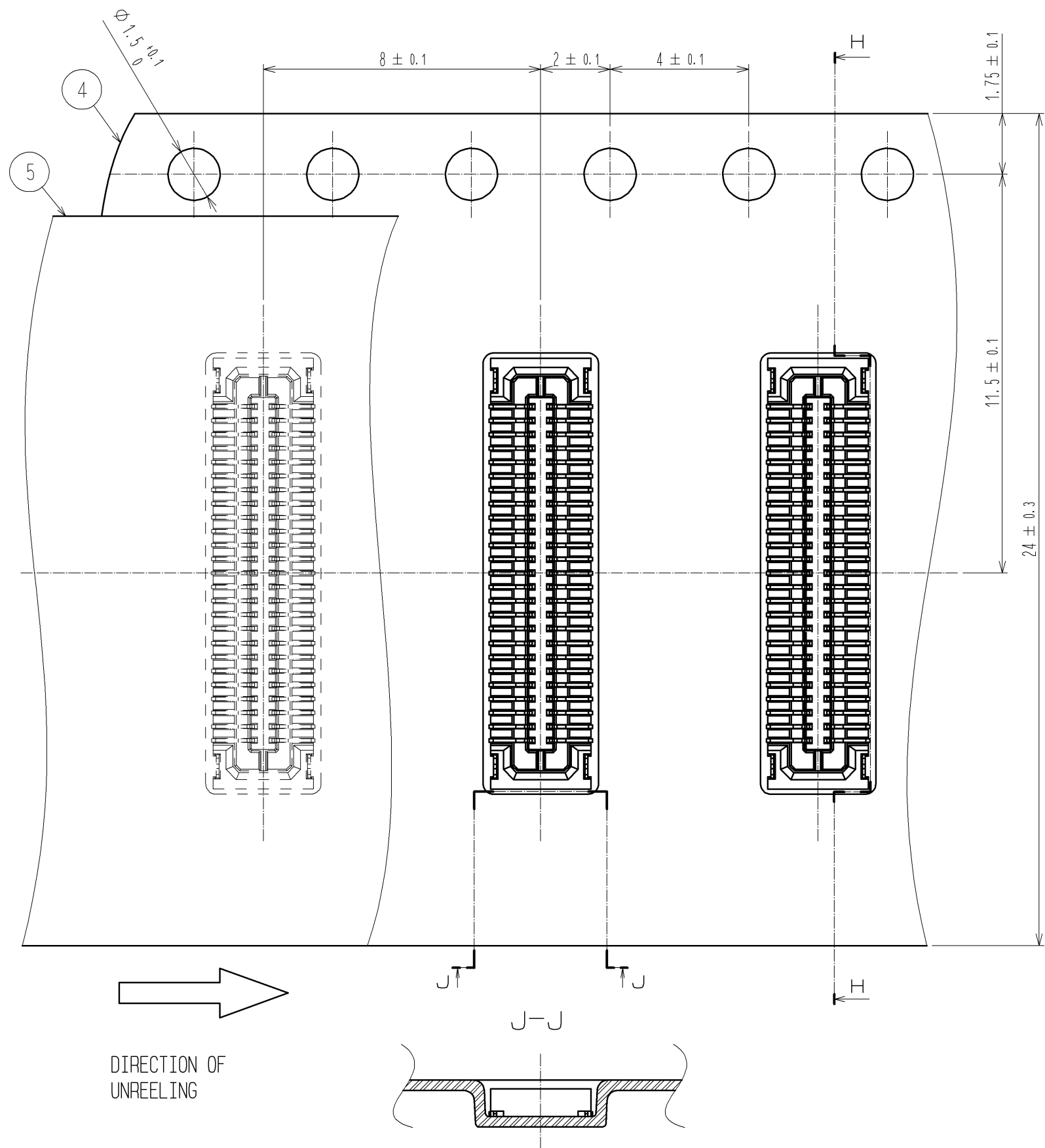

STYLE AND DIMENSION OF REEL (FREE)

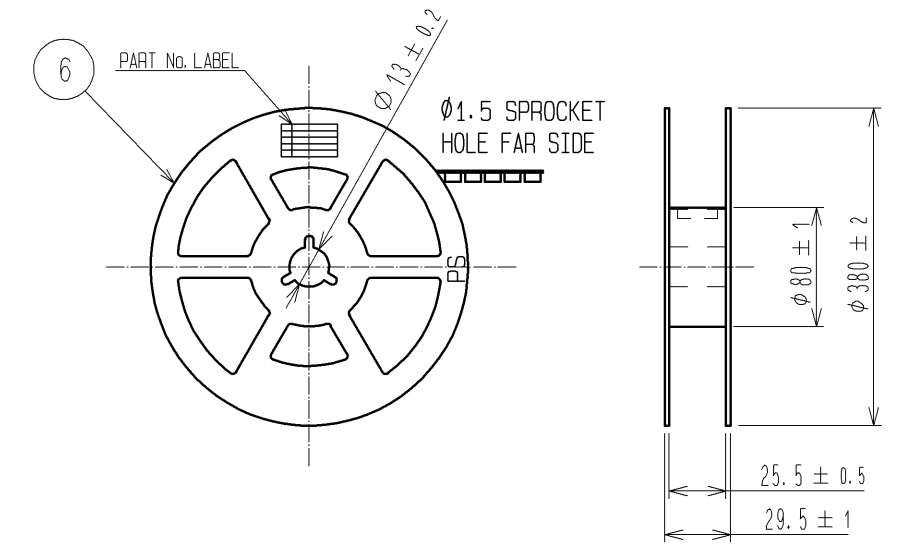

DETAIL OF PART No. LABEL

SUPPLIER	
QUANTITY	
PART NO.	
CODE NO.	
DATE OF MANUFACTURED (YEAR-MONTH-DAY)	
生産月日	年 月 日
☑番	CL684-6102-6-51
品名	BM10NB(0.8)-50DS-0.4V(51)
納入数量	8000個
納入者	ヒロセ電機(株)

HRS	DRAWING NO.	EDC3-318072-01
	PART NO.	BM10NB(0.8)-50DS-0.4V(51)
	CODE NO.	CL684-6102-6-51
		2/2